

## S Series Hopper Loaders

*For central vacuum systems*

### Features:

- Made of 304 Stainless Steel
- Size range from 2 to 40 liters
- For granules and powders
- 50mm material inlet pipe
- Automatic pendulum flap with magnetic sensor
- Non-return flap on the material inlet pipe
- Material level proximity sensor



### Options:

- Dust filter with automatic cleaning for powder conveying
- Automatic “Blow-Back” for self cleaning
- Proportional-valve
- Multi directional hinged lid



**Volume Specifications (by material type):**

Hopper Model	S160	S230	S300	S300H	S380
Granules	1.5	7	14	28	40
Powder	—	—	—	14	25

Standard Hopper Loaders

S380 Family

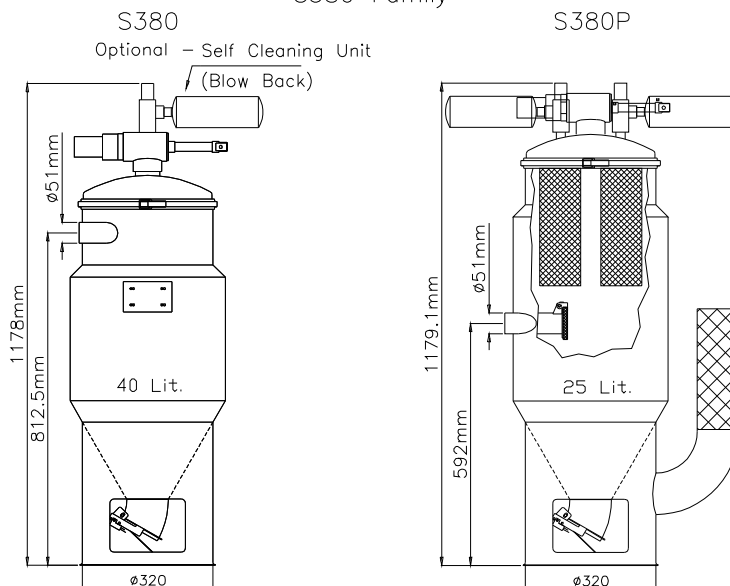

S300 Family

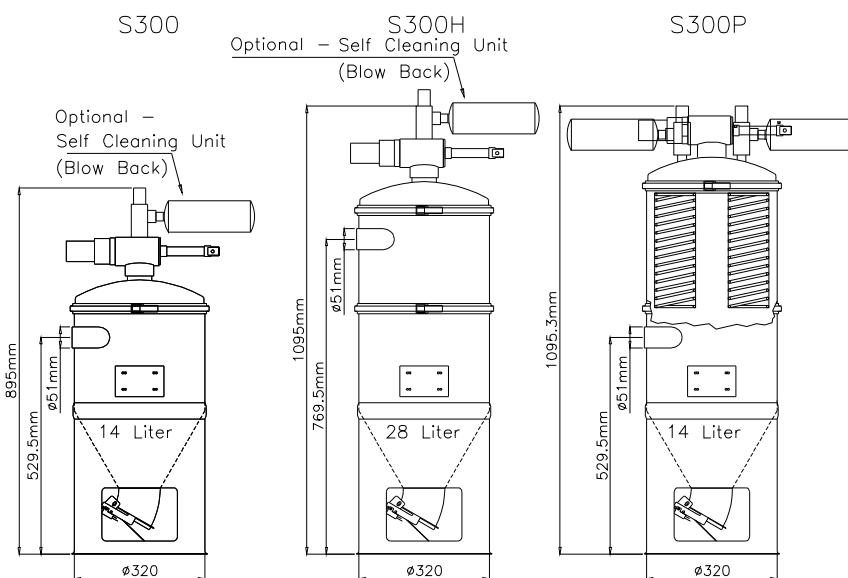

S230 Family

